

August 18, 2013

Introduction

Now that the **European Directive on Alternative Investment Fund Managers** (AIFMD) went live on 22 July 2013 and into the one transition period, FCA has issued advice and clarification in a number of areas on its AIFMD Latest News Page to assist firms in their AIFMD preparation. The national laws of the 27 Member States of the European Union (EU) and the three additional European Economic Area (EEA) states (Norway, Iceland and Liechtenstein) by 22 July 2013 are required to comply and implement. The European Commission published on 19 December 2012 a **delegated regulation**, supplementing AIFMD, which sets out further detail around certain other provisions in AIFMD (the Level 2 Regulation) and is directly applicable in the Member States without the need for implementation. AIFMD has significant implications for hedge fund managers based not only within but also outside the EU, not least hedge fund managers in the US and other jurisdictions who wish to market “Alternative Investment Funds” (AIF), such as Cayman Islands funds, to professional investors within the EU.

The objective of AIFMD is to introduce a common regulatory regime for unregulated funds in the EU (i.e. for any fund that is not an EU UCITS fund) with a view to increased investor protection and to enable European regulators to have increased information in relation to funds being marketed into the EU to enable better monitoring of systemic risk issues.

This document looks at the top ten things a US hedge fund manager needs to know about AIFMD from 22 July 2013. This document assumes a US investment adviser/hedge fund manager, which acts as discretionary investment manager to one or more offshore funds domiciled outside of the EU e.g. in the Cayman Islands, which it actively promotes to investors into the EU, and/or has EU investors who are invested in its funds, as a result of reverse enquiry or reverse solicitation. It also considers the position of any UK/EU affiliate of the US hedge fund manager which performs investment management activities on a delegated basis.

1. When does AIFMD apply?

- 22 July 2013 Deadline for EU Member States to implement AIFMD
- 22 July 2013
- 22 July 2015 (see Q8.2 below)
- 22 July 2018 (see Q8.3 below)

Additional transparency requirements and cooperation agreements must be in place for non-EU AIFM to continue to do active marketing and rely on national private placement regimes (NPPRs) Marketing passport may be extended to non-EU AIF (or EU AIF managed by non-EU AIFM). US hedge fund managers wishing to take the benefit of the EU wide marketing passport would need to become authorized.

Existing NPPRs potentially switched off from this date. If they are, US hedge fund managers wishing

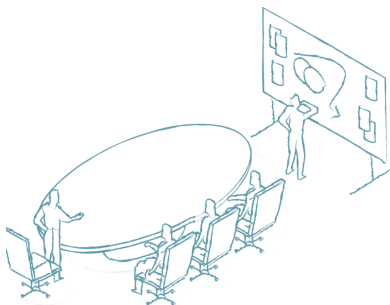

to market an AIF in the EU would need to become authorized.

If a US hedge fund manager actively markets an AIF into the EU on or after 22 July 2013, it will need to comply with some parts of AIFMD as from that date. But it will not be possible for such a non-EU AIFM to become authorized at that stage. Only from 22 July 2015 might a US hedge fund manager have the option, should it wish to do so, to become fully authorized. From 22 July 2018 it may be the case that a US hedge fund manager must be authorized if it wishes to market funds into the EU.

2. Who does AIFMD apply to?

It applies to managers of any fund that is not an EU regulated UCITS fund; a so-called AIF. Such managers are referred to as Alternative Investment Fund Managers (AIFM).

A US hedge fund manager may be an AIFM (see Q3 below), but as a non-EU AIFM, AIFMD will only apply to that US hedge fund manager if it actively ‘markets’ (see Q6 below) one or more of the AIF that it manages to investors in the EU. In respect of hedge fund managers in the US, AIFMD applies to any AIFM which markets one or more AIF in the EU; irrespective of whether the AIF is an EU domiciled AIF or a non-EU domiciled AIF.

US hedge fund managers should note though that it is open to individual EU Member States to apply AIFMD rules to AIF domiciled in that Member State, even if the manager is a non-EU AIFM; Ireland, for example, is consulting on such a proposal. An EU affiliate of a US hedge fund manager could be the AIFM (instead of the US hedge fund manager itself) depending on the nature of its activities (see Q5 below).

3. Is a US hedge fund manager an AIFM?

If the US manager meets the criteria below, then it is likely to be an AIFM unless an exemption applies. See Q5 below for more on exemptions.

An AIFM is defined in AIFMD as being any legal person whose regular business is to provide investment management services (portfolio management or risk management) to one or more AIF (wherever they are domiciled). Although it is only necessary for one of the activities of portfolio management or risk management to be present in order to render an entity an AIFM, an entity cannot be authorized as an AIFM to carry out portfolio management services without also carrying out risk management services and vice versa (this will not be relevant to US managers until 2015 at the earliest).

Is the US manager providing these services to an ‘AIF’? See Q4 below.

An AIF can only ever have one AIFM. Questions then arise as to whether an EU affiliate of a US manager may instead be treated as the AIFM. See Q5 below.

4. What is an AIF? For example, is a Cayman Islands hedge fund an AIF?

AIFMD defines an AIF as any collective investment undertaking whether open-ended or closed-ended (wherever it may be domiciled) which: (i) raises capital from a number of investors with a view to

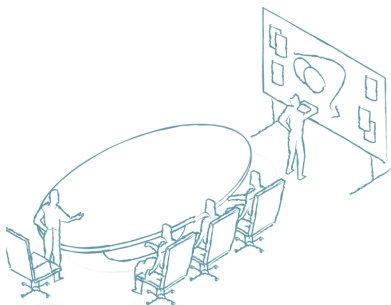

investing it in accordance with a defined investment policy for the benefit of those investors; and (ii) is not a UCITS fund.

This definition of an AIF captures the following:

- most hedge funds/funds of hedge funds, private equity funds, listed closed-end funds, real estate funds, infrastructure funds, commodity funds, long only funds which are not UCITS funds as well as other non UCITS retail funds
- feeder funds and master funds in a master-feeder structure but excludes:
 - single investor funds (subject to certain requirements)
 - managed accounts (so long as the client is not an AIF)
- family offices which do not raise external capital and securitisations special purpose vehicles

As such most typical Cayman Islands established hedge funds, whether in corporate or limited partnership form, will be an AIF under AIFMD.

5. Is an EU affiliate of a US hedge fund manager an AIFM? (Letter-box entities and exemptions)

If the EU affiliate does not exercise investment management discretion, but only provides investment recommendations and/or executes trades, then it will not be an AIFM.

AIFMD also contains exclusions under which AIFM may be exempt from compliance with AIFMD and from authorization as an AIFM where the relevant entity has assets under management (AUM), including any assets acquired through use of leverage, of less than the amounts specified in AIFMD. Therefore if the total value of the AUM, including leverage, where investment discretion/management is delegated to the EU affiliate is less than EUR 100 million, then the affiliate would be exempt from authorization as an AIFM in any event. In practice very few managers will be able to rely on this exemption. The Level 2 Regulation sets out further detail on the method of calculation of AUM. But note that even if exempt from authorization under AIFMD, local regulators still have powers to regulate sub-threshold managers and additional registration/filing requirements will apply.

As mentioned above, each AIF may only have one AIFM.

- Where the US hedge fund manager is the principal investment management entity, and the EU affiliate is a delegate, the US hedge fund manager would be the AIFM unless it had delegated the investment management functions to such an extent that it ceased to be considered to be managing the AIF, and was considered a 'letter-box entity'
- The Level 2 Regulation sets out the criteria for such an assessment, including whether the AIFM no longer retains the necessary resources and expertise to supervise the delegated tasks effectively,
- and/or has delegated the performance of the investment management functions to such an extent that exceeds by a substantial margin the investment management functions performed by the AIFM itself
- The Level 2 Regulation also sets out a number of further qualitative criteria in relation to this assessment, including whether the delegate is in the same corporate group as the AIFM. The assessment is made on a fund by fund basis

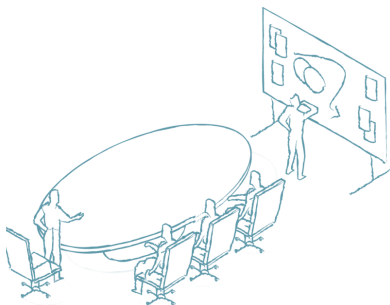

It is conceivable that where the US hedge fund manager is responsible for the management of a number of funds, and one, for example, has a European focussed strategy, the management of that fund could be delegated to such an extent that the affiliate could become the AIFM for that fund. There currently remains uncertainty around the delegation rules, notwithstanding the Level 2 Regulation, and an analysis will be required of the extent of the delegation and the activities and supervision retained, particularly in relation to risk management, by the US hedge fund manager.

If the EU affiliate is directly appointed by a fund established by the US hedge fund manager and exercises investment management discretion in relation to that fund, e.g. in relation to a European long/short equities strategy fund, then it is likely to be an AIFM in relation to that fund even if it delegates to the US parent a large proportion of the risk management activities in relation to that fund.

6. What is “marketing” under AIFMD and why does it matter?

AIFMD will only, prior to 2015, apply to a US hedge fund manager if it is “marketing” one or more AIF into the EU. It matters if a non-EU AIFM is marketing an AIF into the EU because it is the marketing activity that triggers the transparency/reporting requirements under AIFMD (see Q8 below) even if no investors result from such activity.

For the purposes of AIFMD, “marketing” is defined as the direct or indirect offering or placement, at the initiative of the relevant AIFM, or on behalf of the relevant AIFM, of units or shares of an AIF that it manages to or with EU investors. Passive marketing, which would include what is often referred to as “reverse enquiry”/“reverse solicitation”, is not restricted by AIFMD and can continue on or after 22 July 2013 where it is recognized as a concept and permitted by the relevant local national law in a Member State. Investor Relations activity for existing investors would also not be caught.

Since AIFMD did not provide for the definition of marketing to be further elaborated by the European Commission in the Level 2 Regulation, it will be up to each individual Member State when transposing AIFMD into its national law to determine whether to refine and/or expand on the definition used in AIFMD. However, EU Member States currently apply different tests to define reverse enquiry/reverse solicitation and the current patchwork of approaches in the EU is likely to remain.

“Cap intro” events may be capable of being organized such that they are not regarded as “marketing” within AIFMD on the basis that no offering document or other marketing material is provided to investors at this point in time. However individual Member State rules will govern whether any investor approach following the event would be treated as a reverse enquiry such that if information was then subsequently sent to the investor, it would not then be treated as “marketing”.

Introduction of investors to the AIFM by consultants, such as the large pension fund consultants, should, in the absence of any arrangement or agreement between the AIFM and the consultant, not be treated as marketing. Again, the position will be blurred if the AIFM has given marketing information or material to the consultant, even if the offering document itself is not provided. There is a risk that such arrangements with the consultant could be treated as indirect marketing. Monitoring of local implementation is key here.

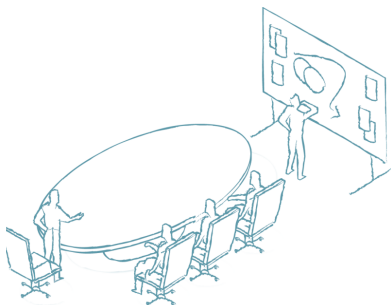

7. What investors are covered by AIFMD?

AIFMD applies to the marketing of AIF to professional investors within the EU but the marketing of AIF to retail investors is not regulated by AIFMD. The EU wide marketing passport which is provided for under AIFMD does not apply to marketing to retail investors, but each Member State will be free to permit both EU and non-EU AIFM to market to retail investors, although very few do currently and, for example, the UK is consulting on the introduction of a new regime that would restrict further the promotion of unregulated funds to retail investors.

8. What new rules will apply from July 2013 to the marketing of an AIF, such as a Cayman hedge fund, into the EU by a US hedge fund manager?

The rules applicable to when a US hedge fund manager (which is an AIFM) must, or is permitted to, become authorized under AIFMD and to use the EU wide marketing passport provided for by AIFMD can be divided into at least three phases: 2013 to 2015; 2015 to 2018; and 2018 onwards.

By 22 July 2015, ESMA is required to provide advice to the Commission on the functioning of the EU wide marketing passport and the existing NPPRs (as, potentially, amended). Phase 2 and phase 3 will each be dependent on the outcome of the Commission's response to ESMA's advice. It will not be until the Commission has acted on ESMA's advice (which it is not bound to follow) and implemented secondary legislation (additional "level 2 measures") that the next phase will commence.

8.1 Phase 1: 22 July 2013 onwards

(A) National private placement regimes to continue

The majority of US hedge fund managers currently market AIF into the UK and other EU Member States by way of the national private placement regimes (NPPRs) of the relevant jurisdiction and AIFMD permits the retention of these regimes in all EU Member States for the promotion of AIF to professional investors by such non-EU AIFM until at least 22 July 2018 (see Q8.3 below). AIFMD also introduces an EU wide marketing passport. However, this passport is unlikely to be available to non-EU AIFM or for non-EU AIF (where the relevant AIFM is EU based) until 22 July 2015 at the earliest.

Accordingly, from 22 July 2013, US hedge fund managers fund raising in the EU will have two choices: (i) to continue marketing by way of the NPPRs; or (ii) to take advantage of the EU wide marketing passport by setting up an EU affiliate which qualifies as an AIFM and which manages an EU AIF (see further Q9). It is expected that most US hedge fund managers will want to follow the former route.

Note that, unless specifically extended by a Member State to retail investors, AIFMD from 22 July 2013 does not permit marketing of AIF within Member States to anyone other than professional investors - being, broadly, institutional investors and individuals who can be, and agree to be, opted up in accordance with the criteria set out under MiFID Annex II. The opt up test requires an individual to meet two out of three tests relating to size of investable portfolio (greater than EUR 500,000), frequency of similar investments, and relevant employment in the financial services sector.

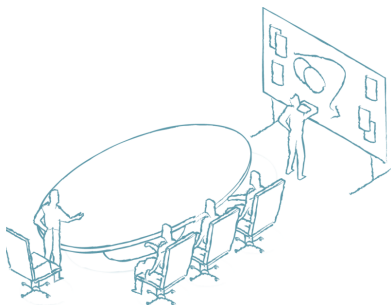

Additionally, AIFMD permits individual EU Member States to impose more restrictive NPPRs, and to impose additional transparency/reporting to regulators. The UK has provisionally indicated its intention to continue to permit the marketing of non-EU AIF to professional investors in accordance with the UK's current national private placement regime subject to compliance with the minimum requirements specified in AIFMD. Some other Member States however, e.g. Germany, have indicated that they will aim to withdraw their NPPRs.

From 22 July 2013, AIFMD requires that a US hedge fund manager wishing to market an EU AIF or a non-EU AIF, e.g. a Cayman hedge fund, into an EU Member State under the that State's NPPR must also comply with the transparency requirements of Chapter IV of AIFMD (Transparency Requirements) in relation to:

- the publication of an annual report for the relevant AIF (Article 22) ; disclosures to investors (Article 23) and reporting to national regulators (Article 24)
- each discussed further below (Additional transparency and governance requirements will also apply to holdings by such marketed fund in EU non-listed companies – see (D) below.)

The following conditions must also be met:

- there must be bi-lateral cooperation agreements, meeting the requirements of AIFMD and the Level 2 Regulation, in place between (i) the regulatory authorities of each EU Member State where the AIF is marketed and the supervisory authorities of the non-EU country where the non-EU AIFM is established - in the case of the US, the SEC; and (ii) the regulatory authorities of each such EU Member State and the supervisory authorities of the country where the non-EU AIF is established (e.g. the Cayman Islands Monetary Authority) and
- the US and, if different, then on-EU country in which the AIF (e.g. the Cayman Islands) is established must not be listed as a Non Cooperative Country and Territory by the Financial Action Task Force (FATF). Neither the US nor the Cayman Islands presently are listed and this is not expected to change

(B) Action to be taken by 22 July 2013

Each US hedge fund manager which is itself marketing an AIF into the EU (or uses one or more third parties who market an AIF into the EU) will need to ensure that it complies with the following Transparency Requirements:

- Prior disclosure to investors: immediately from 22 July 2013 the US hedge fund manager will need to comply with the requirements of AIFMD with respect to disclosure to investors before they invest in the relevant AIF. This will require the US hedge fund manager which is marketing an AIF in the EU to disclose to investors prior to investment (and whenever there are any material changes therein) certain specified information including, for example, information on strategy, leverage, performance

Article 23 AIFMD sets out the detailed list. Much will already be covered in the offering document for the fund, and can be supplemented with a separate AIFMD disclosure document (or by disclosure

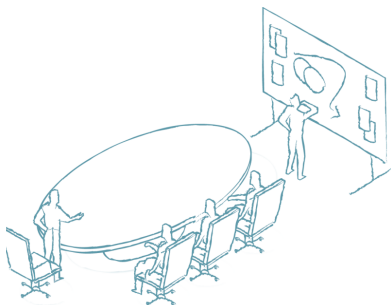

in a monthly or quarterly newsletter), particularly for information like performance which would not usually be included in an offering document and may require more frequent updating.

Report to national regulators-to comply with the requirements of AIFMD relating to reporting to national regulators, such as the FSA in the UK, a US hedge fund manager will be required to make disclosures, amongst others, relating to the overall level of leverage employed where leverage is employed “on a substantial basis” (broadly, three times NAV for this purpose) and report on the main instruments in which it trades on behalf of each AIF and on the principal exposures and most important concentrations of the relevant AIF. The Level 2 Regulation sets out a pro-forma reporting template which must be used. It will not be possible to use Form PF as the reporting format under AIFMD Reporting will be at least half-yearly, within one month following the end of the calendar half-year in relation to a fund with a December year end. For those managers whose AUM exceeds EUR 1 billion, reporting will be quarterly. For a hedge fund manager which is a non-EU AIFM, this threshold is measured by reference to the AIF marketed into the EU, not by reference to the total AUM of that hedge fund manager.

Although there is some lack of clarity in the Level 2 Regulation, we consider that the first such report would be made within one month after the first calendar quarter or half year, so by end October 2013 for quarterly reporting, and by end January 2014 for half-yearly reporting. ESMA and local regulatory implementation should be monitored for any varying approaches.

Annual report-within six months following the end of the financial year of the relevant AIF a US hedge fund manager which is an AIFM must, in respect of that AIF, make available an annual report to investors and the national regulators of each Member State into which the AIF is marketed. The annual report must contain, amongst other things

- the total amount of remuneration for the financial year, split into fixed and variable remuneration, paid by the US hedge fund manager to its staff members, and number of beneficiaries and
- the aggregate amount of remuneration broken down by senior management and members of staff of the US hedge fund manager whose actions have a material impact on the risk profile of the relevant AIF

The Level 2 Regulation requires, where the information is available, for this remuneration information to be broken out in relation to each AIF, and, as AIFMD only applies to those AIF being marketed into the EU, the remuneration disclosure could be limited to the relevant part applicable to the individuals involved in the activities of the AIF which is being marketed. Where a US hedge fund manager has the majority of its AUM invested through its US domestic funds, then it would be possible to attribute and disclose a relatively smaller proportion of the remuneration to the AIF being marketed.

Strictly the reporting is only to investors in the EU Member States where the AIF has been marketed. But, consideration will have to be given to issues of fair treatment as to whether the annual report

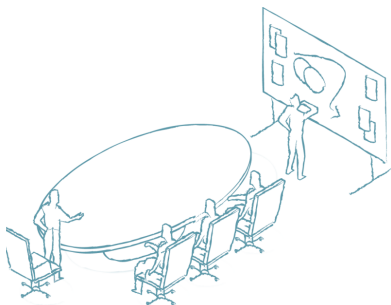

should be made available to all investors in that fund.

The first annual report should be made available, in respect of AIF with a December year end, within six months following 31 December 2013. This annual report will need to be supplied as part of the prior disclosure document from that time.

Note that the Transparency Requirements apply in respect of any AIF marketed into the EU – such that the annual reporting will be triggered even if no investor invests. And, until the US hedge fund manager is able to become authorized in the EU, any reporting must be done to the national regulator in each EU Member State into which the AIF is marketed. Checks must also be made as to the scope of the Transparency Requirements in each Member State as AIFMD gives power to individual Member States to operate the stated Transparency Requirements as a minimum requirement, which may be gold-plated!

(C) Form of cooperation agreement

ESMA has been working on a template cooperation agreement which has been under discussion with relevant supervisory authorities and is now starting to be adopted. This template cooperation agreement is required to meet AIFMD and Level 2 Regulation requirements in terms of data protection, facilitation of onsite inspections by EU national authorities in the home jurisdictions of the non-EU AIFM or AIF, and facilitation of the enforcement of EU legislation in the jurisdictions of the non-EU AIFM and AIF.

(D) Transparency and governance in relation to EU non-listed companies

Note that where the AIF being marketed holds either control (i.e. greater than 50%) or a 10% or more holding in certain EU registered non-listed companies, e.g. which may arise in a hedge fund with side-pockets, certain additional transparency and governance requirements apply.

8.2 Phase 2: 22 July 2015 onwards

(A) ESMA advice

By 22 July 2015 ESMA will review both the operation of the EU wide marketing passport regime (which will commence in 22 July 2013 for EU AIFM in respect of EU AIF) and the NPPRs. Following such review, ESMA will advise the Commission on whether the marketing passport regime should be extended to non-EU AIFM in relation to EU AIF and/or non-EU AIF marketed within the EU. Depending on the outcome of the review and the advice given by ESMA, the Commission may determine, by the adoption of additional Level 2 measures, within three months of receipt of the ESMA advice, that a US hedge fund manager may be able to become authorized under AIFMD as an AIFM and so take advantage of the full EU wide marketing passport to market a non-EU AIF, such as a Cayman Islands hedge fund, to professional investors in any or all 27 EU Member States.

If the Commission adopts additional Level 2 measures permitting the authorization of non-EU AIFM in the EU, it will specify the date from which this will take effect. In practice, assuming ESMA only

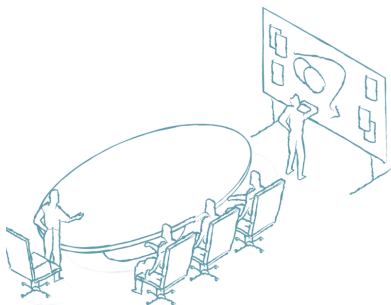

issues its advice in 2015, this is unlikely to be before the end of 2015 at the earliest to allow EU Member States time for implementation. This specified date will be the earliest date from which a US hedge fund manager could be fully authorized under AIFMD.

(B) National private placement regimes still continue

To the extent that the NPPRs remains available within the EU (i.e. unless any individual Member State chooses to abolish its regime), a US hedge fund manager will be able to continue to use that regime to market to professional investors within the EU. The same requirements discussed above which will apply from 22 July 2013 will continue to apply. US hedge fund managers who wish to market AIF (whether EU or non-EU) into the EU should note that there is no obligation to become authorized under AIFMD from 2015 - unless they want to take advantage of the marketing passport to market into any or all 27 EU Member States.

There is a risk that if the authorization and passport regime is extended in 2015 to non-EU AIFM, individual Member States will withdraw their NPPRs, effectively meaning a US hedge fund manager would need to seek authorization as an AIFM in the EU.

8.3 Phase 3: 22 July 2018 onwards

If Phase 2 is implemented and the EU wide marketing passport is made available to non-EU AIFM from 2015, it is possible that ESMA will recommend that NPPRs should cease to be available three years thereafter, i.e. from 22 July 2018 (earliest). This would mean that from that date a US hedge fund manager would only be able to market a non-EU AIF to professional investors using the EU wide marketing passport. Accordingly, if the EU wide marketing passport is granted for AIF in 2015 and the NPPRs are “switched off” in 2018, then US hedge fund managers, who wish to continue to market their non-EU AIF, such as Cayman hedge funds, to investors in the UK (or elsewhere in the EU), will have no choice but to become authorized under AIFMD and be subject to the full application of AIFMD. This may be necessary even where the relevant US hedge fund manager’s assets under management are below the threshold mentioned above (see Q5), if the NPPRs cease to be available.

9. If I want to have the benefit of the EU marketing passport (if available) from 2015, what do I need to do?

In order to benefit from the marketing passport a US hedge fund manager will need to opt in to AIFMD and obtain authorization as an AIFM under AIFMD from the regulatory authorities of an EU “Member State of reference” and to comply with the requirements of AIFMD in full. Where a non-EU AIF, such as a Cayman Islands hedge fund, is being marketed, the US hedge fund manager will also need to comply with an additional condition (in addition to ones similar to those mentioned above in relation to the NPPRs) – namely that there must be a signed cooperation agreement between the country of establishment of the AIF being marketed (i.e. the Cayman Islands) and the Member State of reference and, if different, each other EU Member State in which shares of the non-EU AIF are proposed to be marketed, which complies with the standards laid down in Article 26 of the OECD

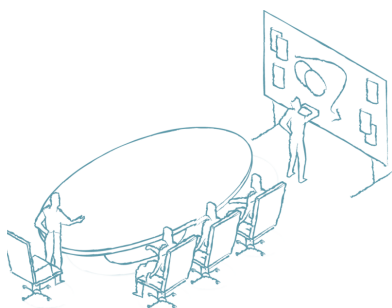

Model Tax Convention and which ensures an effective exchange of information in tax matters. In order to become authorized as an AIFM a US hedge fund manager will need to:

- Identify a “Member State of reference” within the EU. In effect the EU Member State of reference is an adopted EU regulator. If a US hedge fund manager is marketing only in the UK, the UK would be the Member State of reference and the FSA the relevant regulator. However, if marketing is being carried out in EU Member States other than the UK, it is possible that an EU Member State other than the UK would need to be the Member State of reference – AIFMD sets out a number of steps and criteria to determine the Member State of reference, and also provides for the European Commission in due course to adopt additional Level 2 measures to assist in the determination of the Member State of reference if there is more than one possible candidate
- Appoint a “legal representative” established in its EU Member State of reference. The legal representative will be the contact point of the US hedge fund manager in the EU for all regulators and EU investors in the AIF and will have responsibility for performing the compliance function relating to the activities performed by the US hedge fund manager under AIFMD. There is no requirement to establish a branch or other physical presence in the EU to be the AIFM although in practice it may be necessary, if the US manager has no EU affiliate, to establish one to act as such “legal representative”.

10. What are the consequences of authorization under AIFMD for a US hedge fund manager?

In the event that, in due course, a US hedge fund manager wishes to become authorized under AIFMD the full requirements of AIFMD would need to be complied with in respect of each EU AIF which it manages and each non-EU AIF which is marketed into the EU by the AIFM or on its behalf. The application of AIFMD would not extend to non-EU AIF, such as domestic US funds, which are not managed, nor marketed, in the EU.

